

LSAA
LIGHTWEIGHT STRUCTURES ASSOCIATION OF AUSTRALASIA

LSAA 2011 Conference
13th October 2011

**Tensile Structure Engineer's
Perspective on Collaboration**
Peter Lim - Tensys

www.tensys.com

1

In An Engineer Imagines,

*Peter Rice believed that the limits of what
can be designed and built are the
limitation of materials and the limitation of
the designer's inventiveness, not the
case of limitation of analysis and
specification methods*

www.tensys.com

2



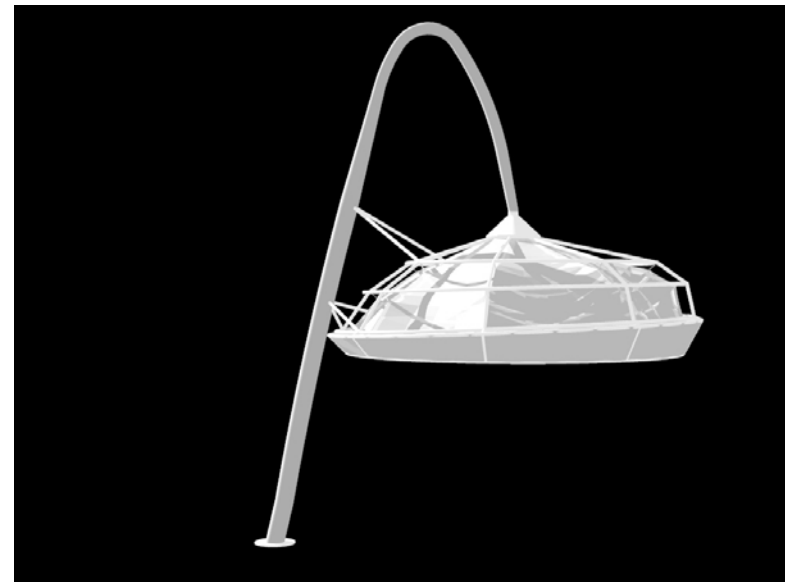
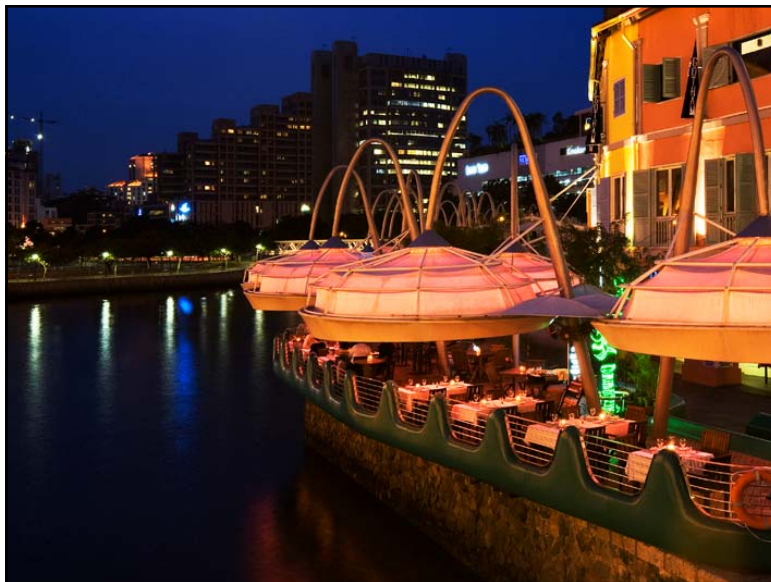

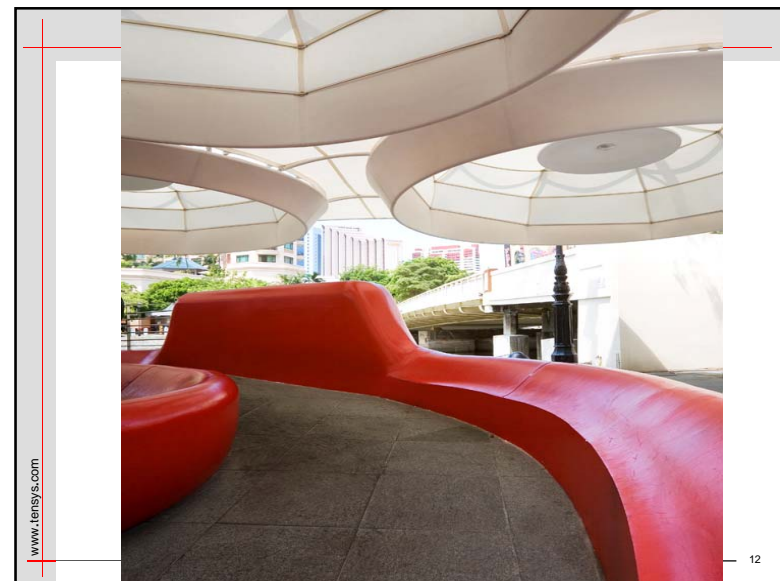
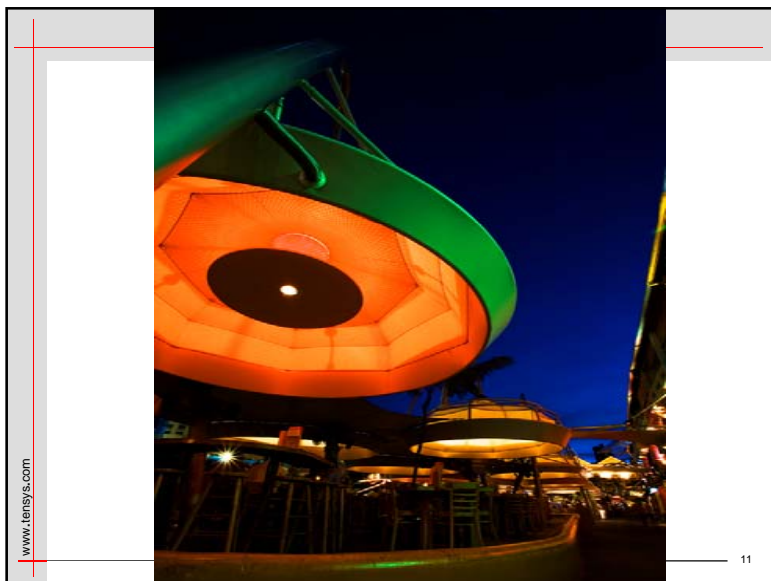
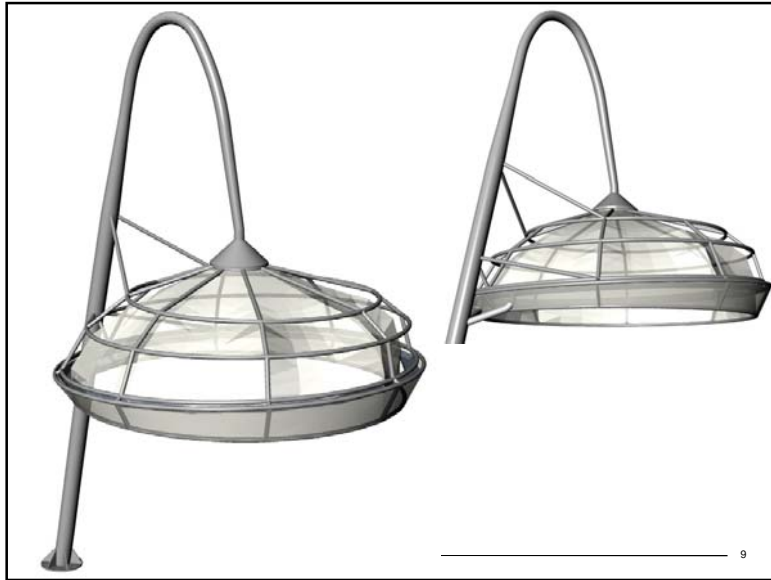

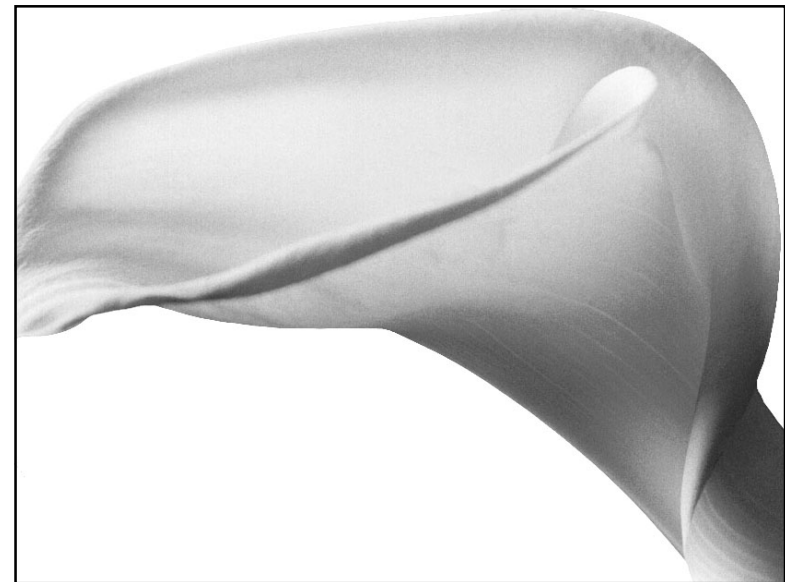

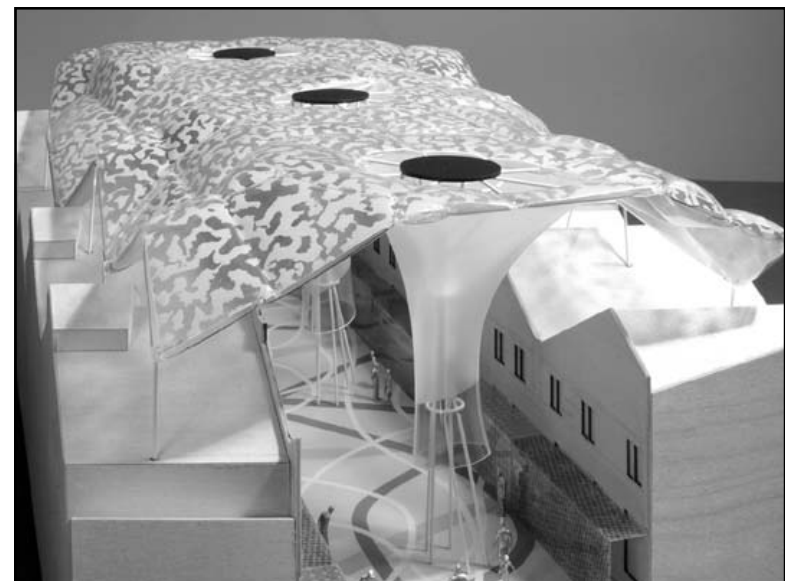

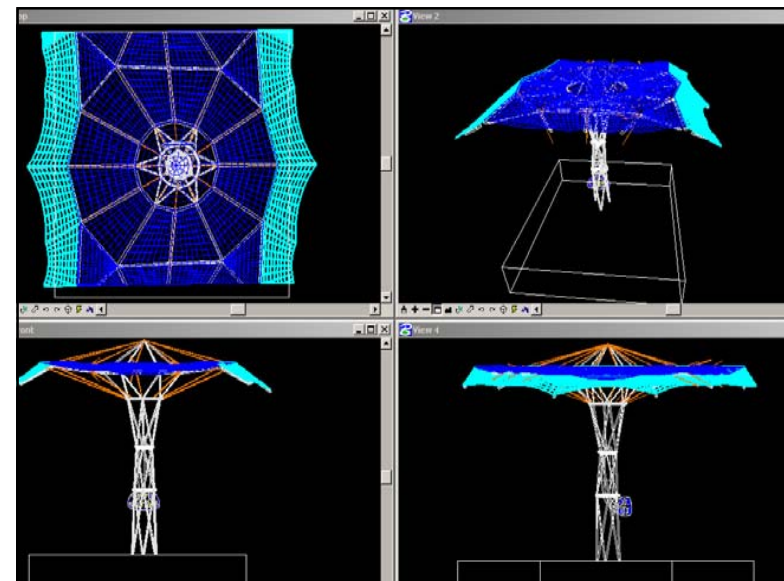
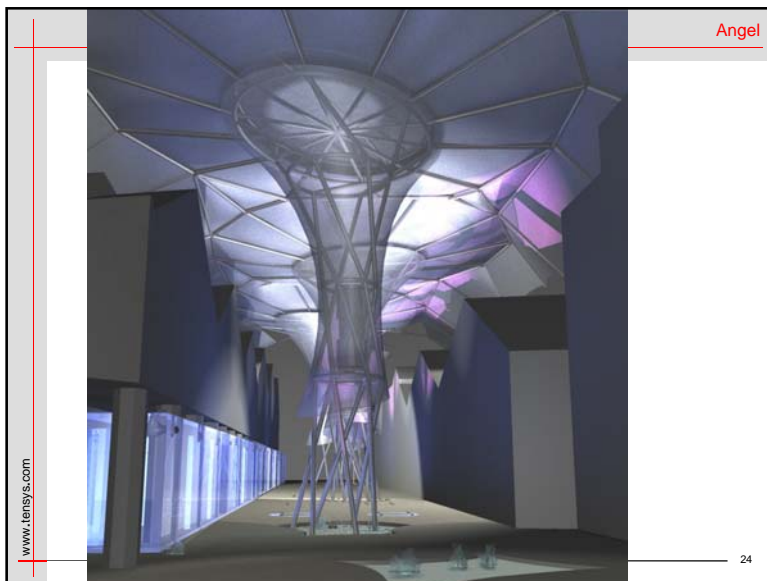
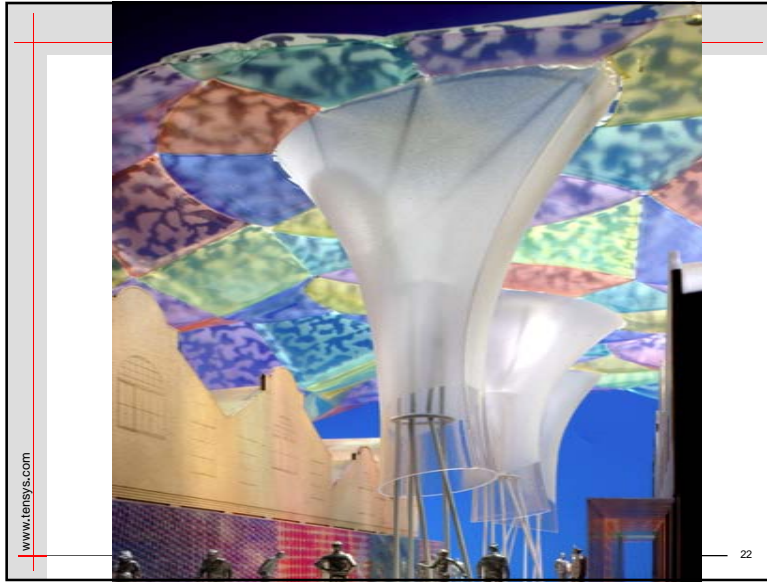

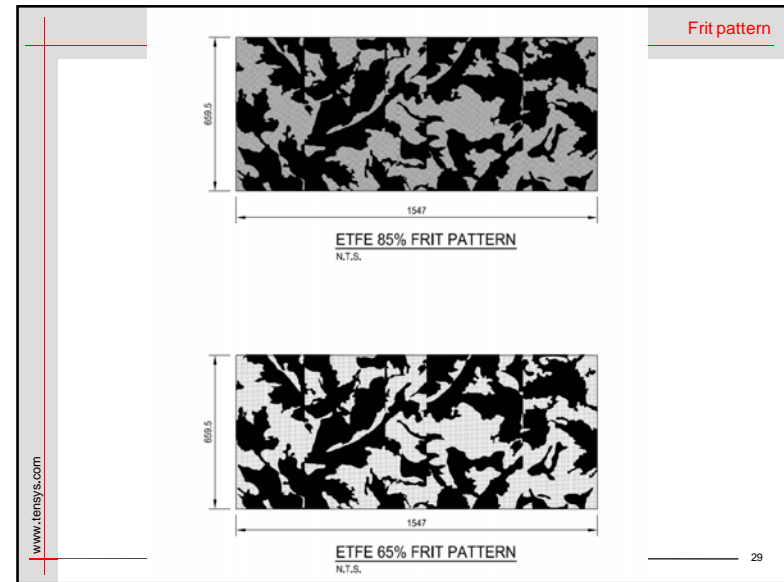
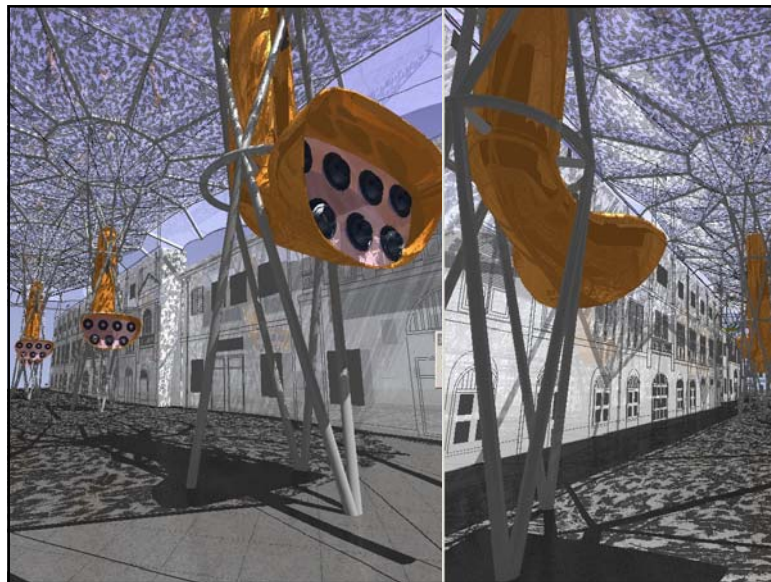
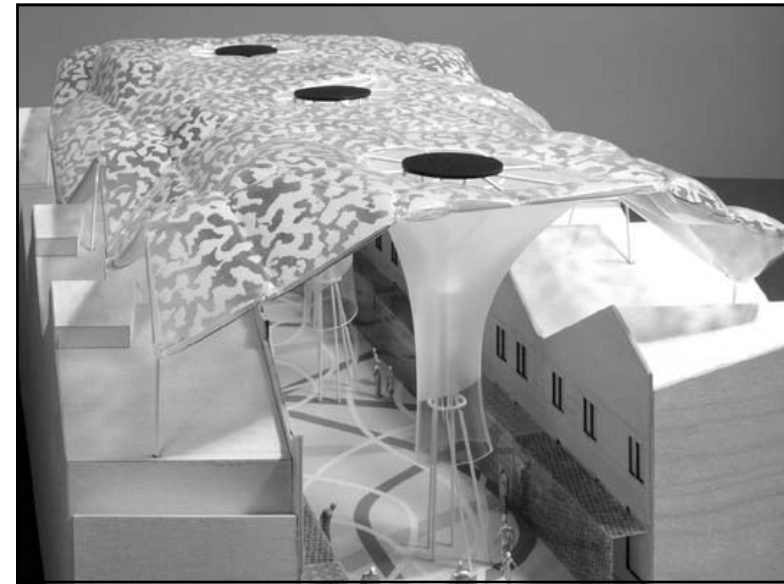
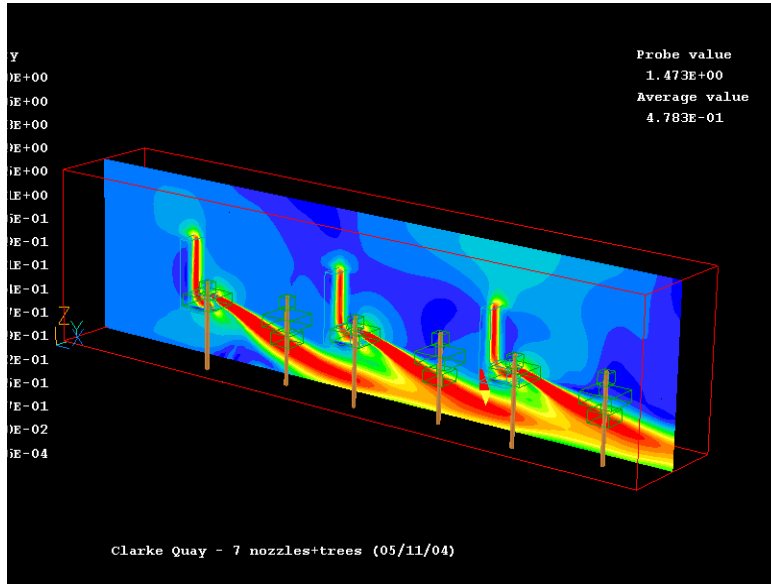

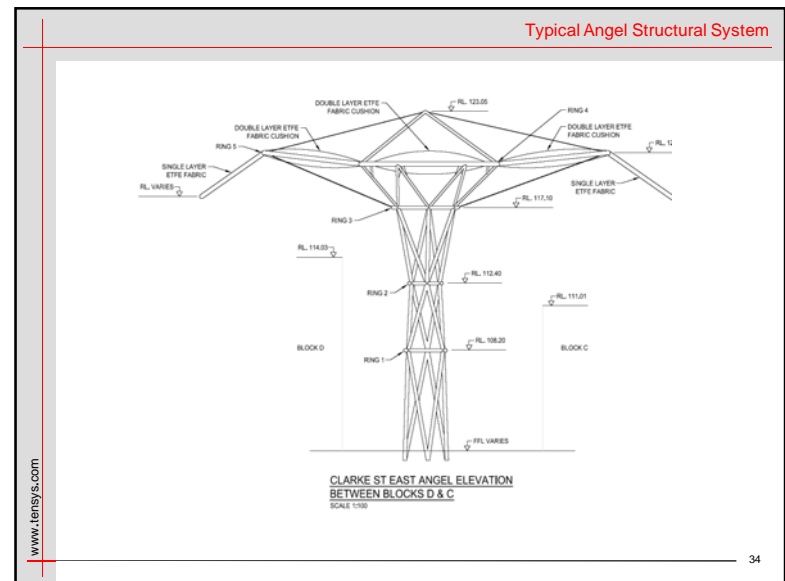
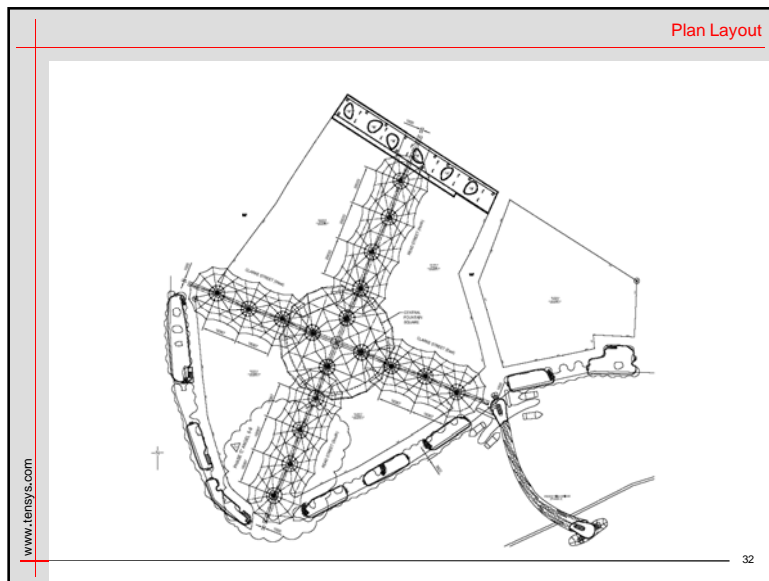
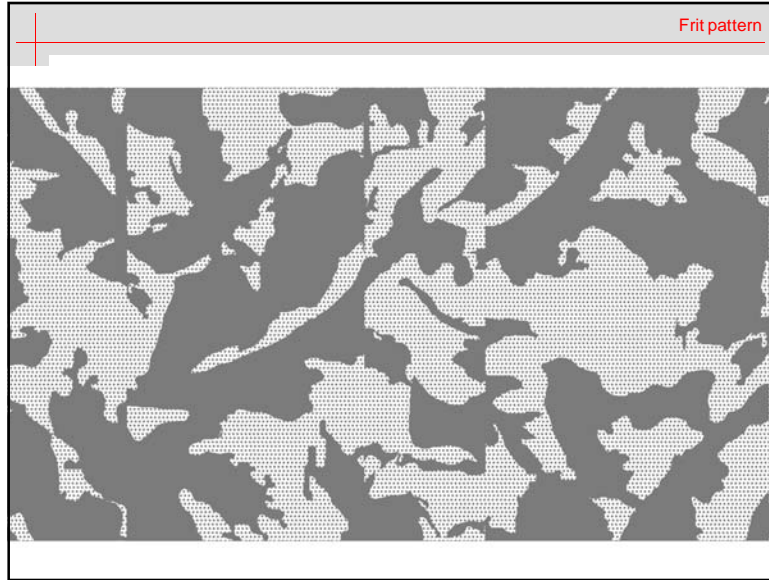

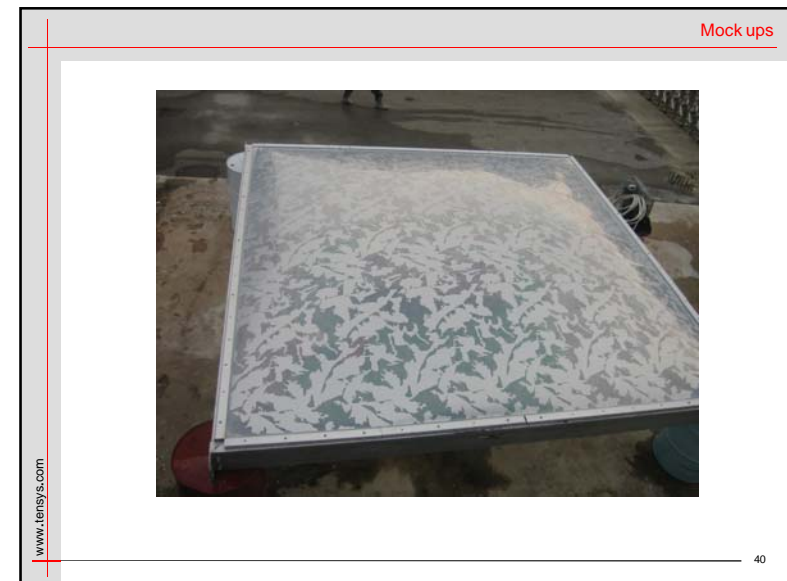
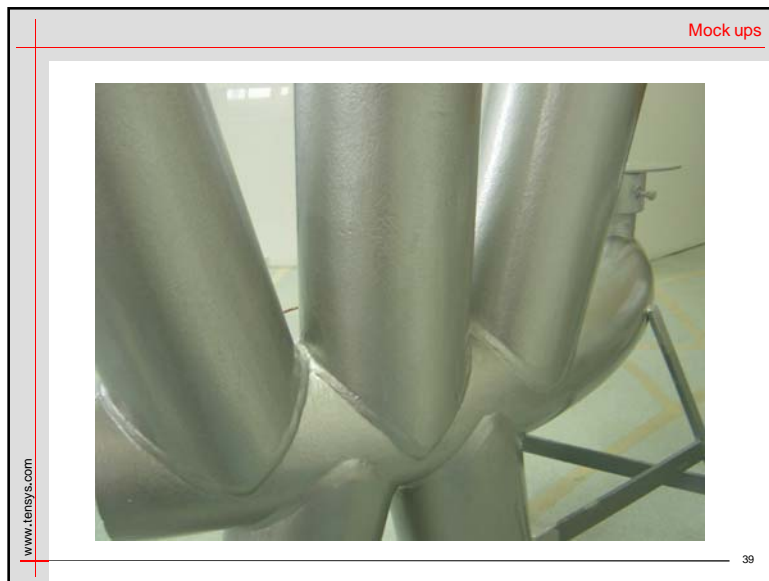
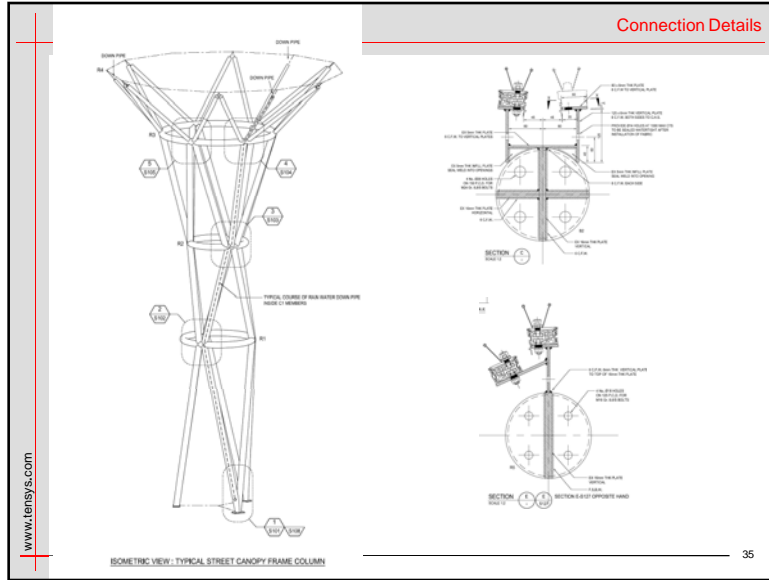

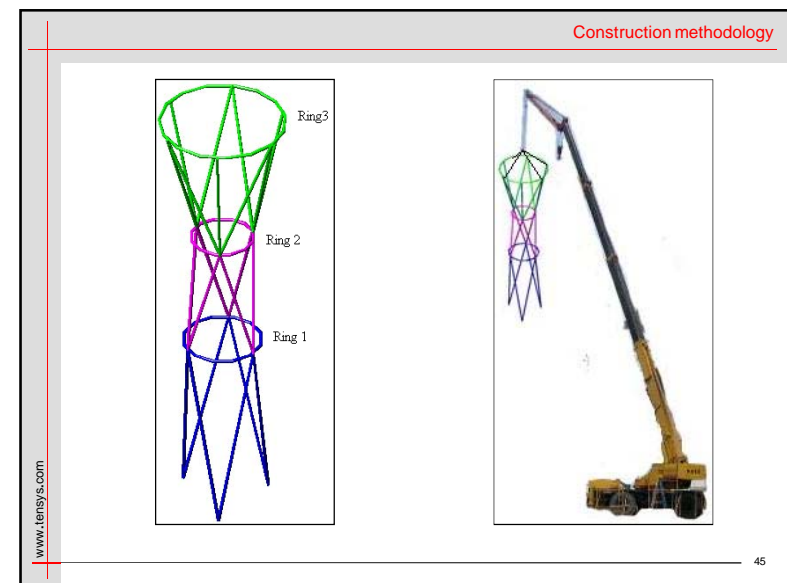
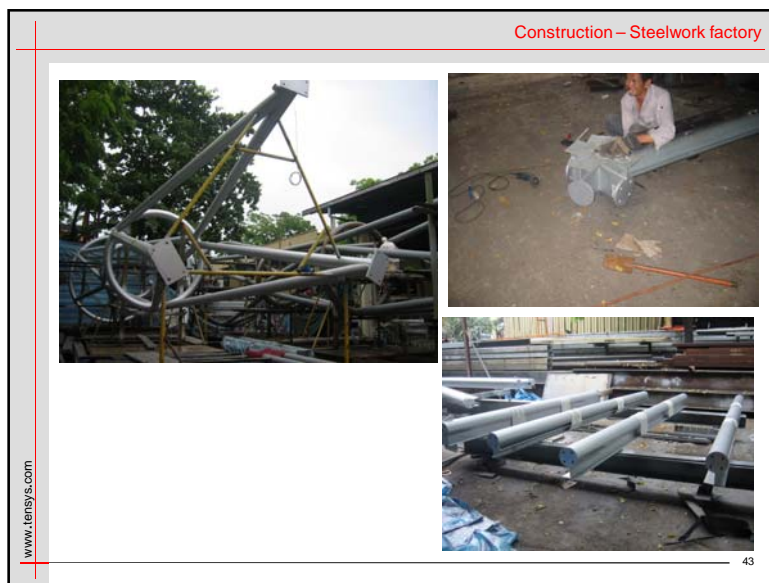
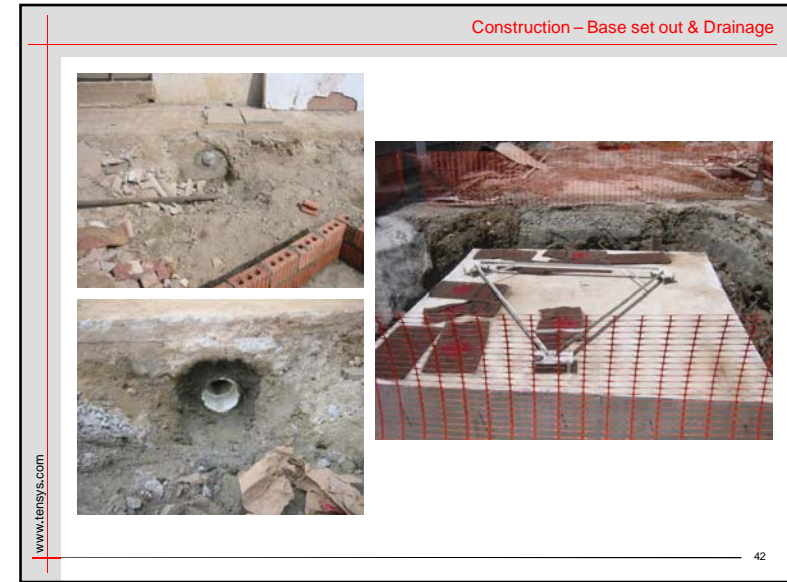

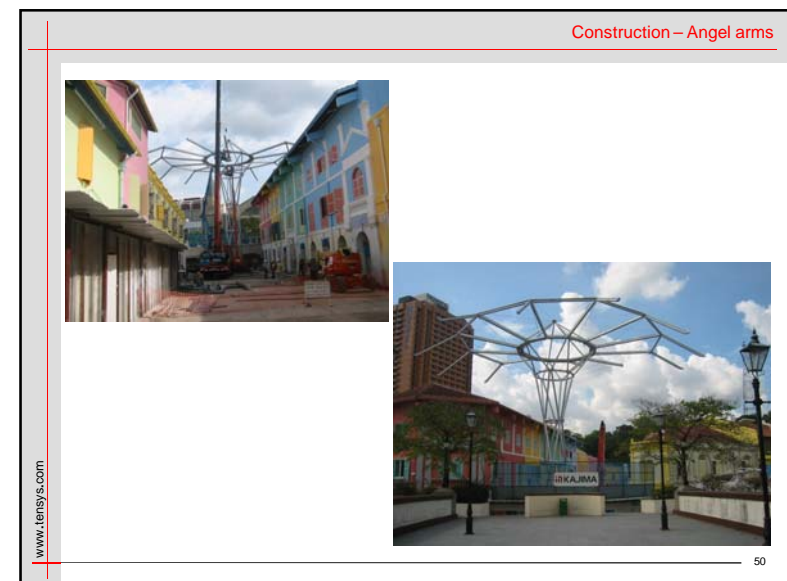
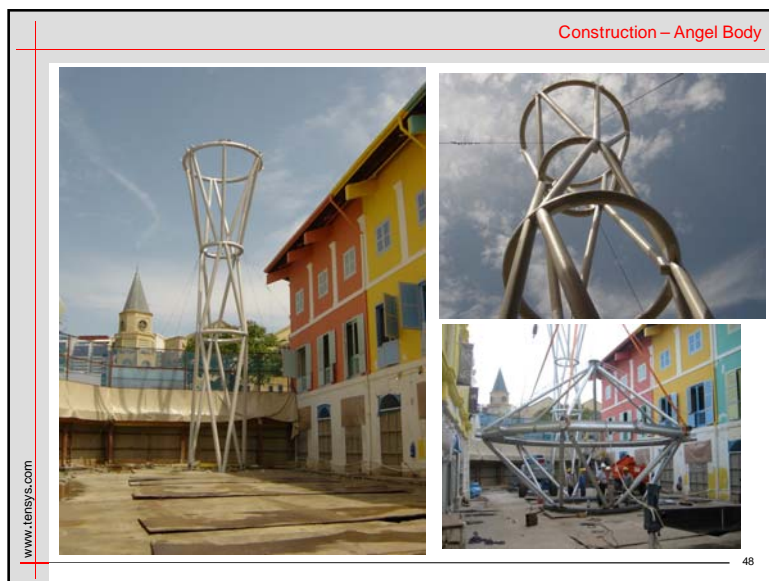
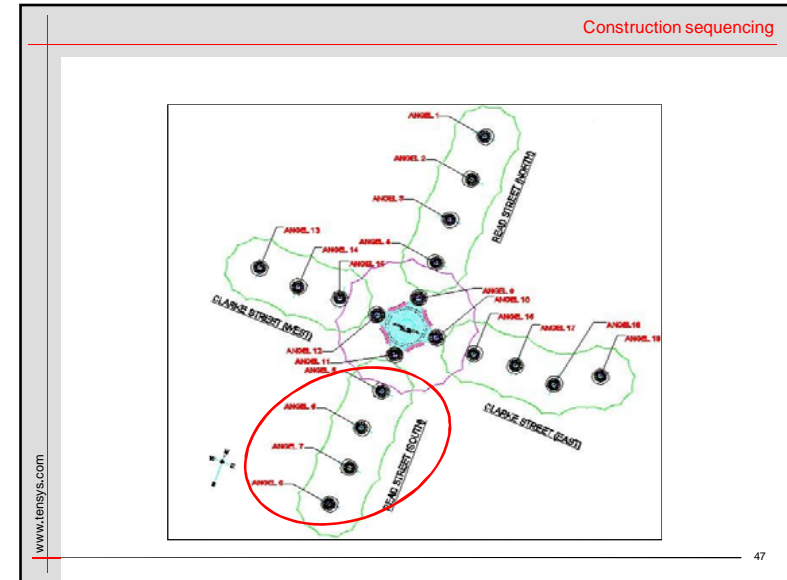
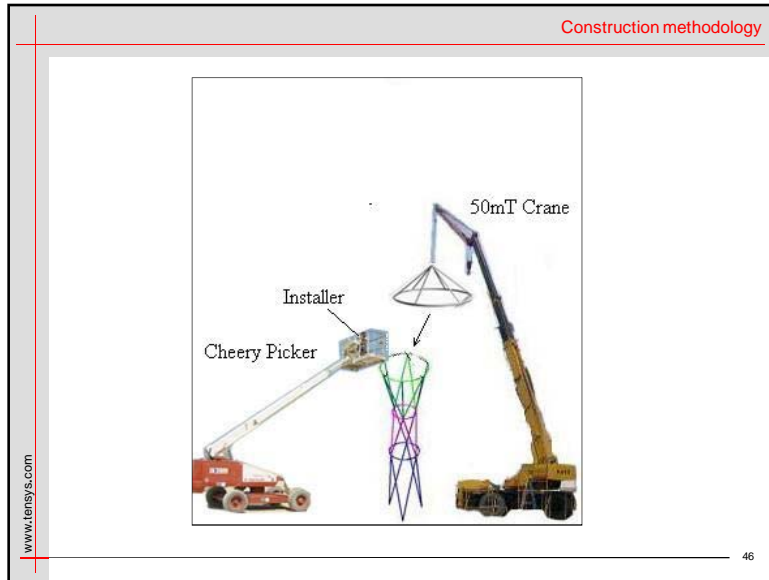

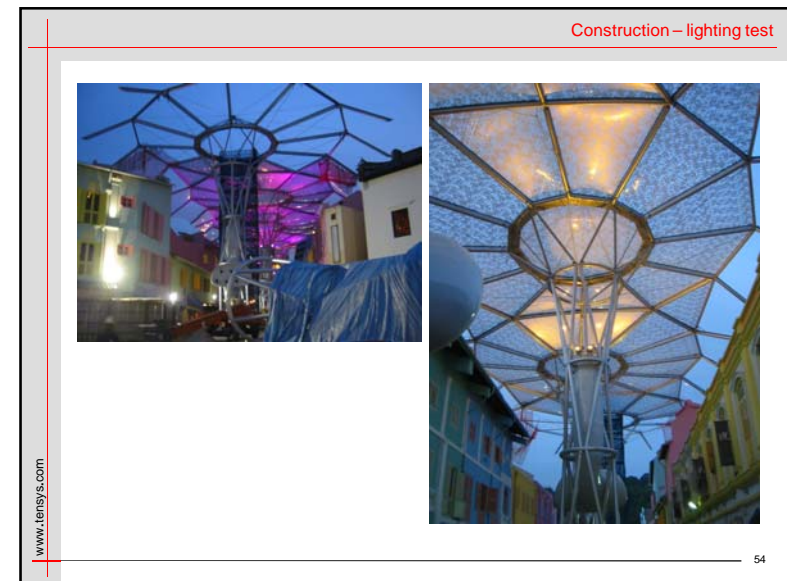
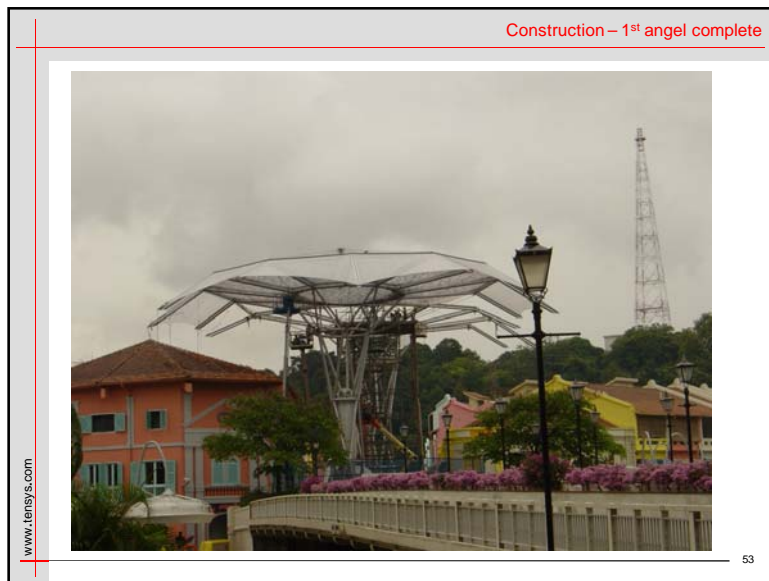
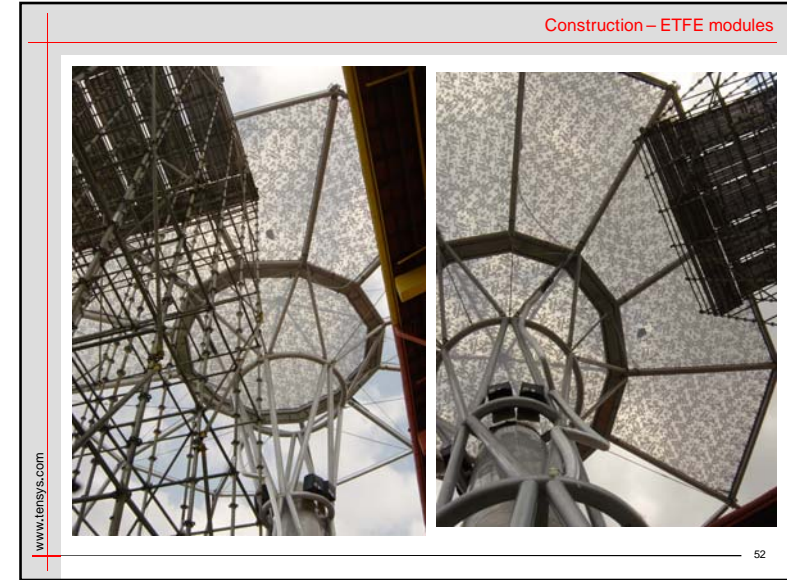

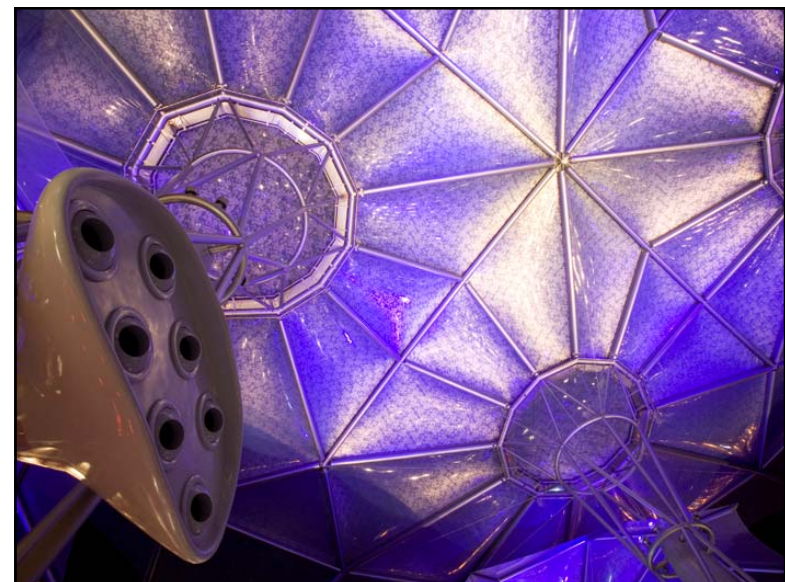
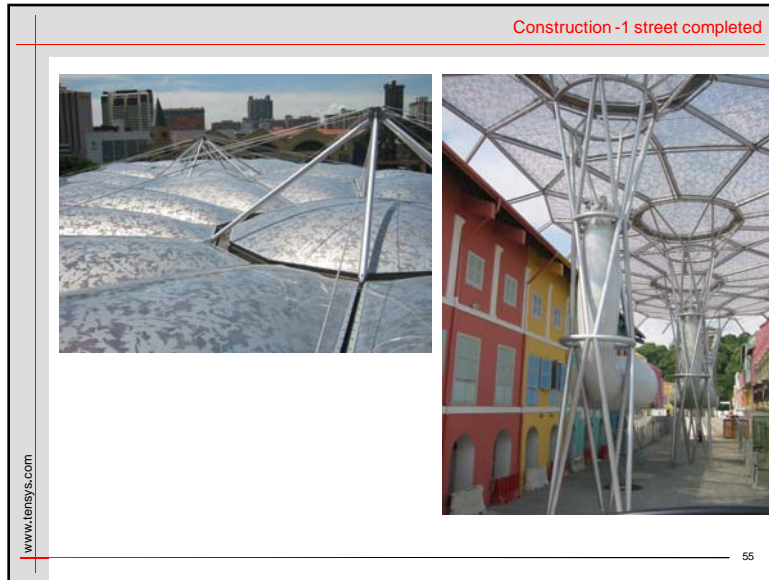

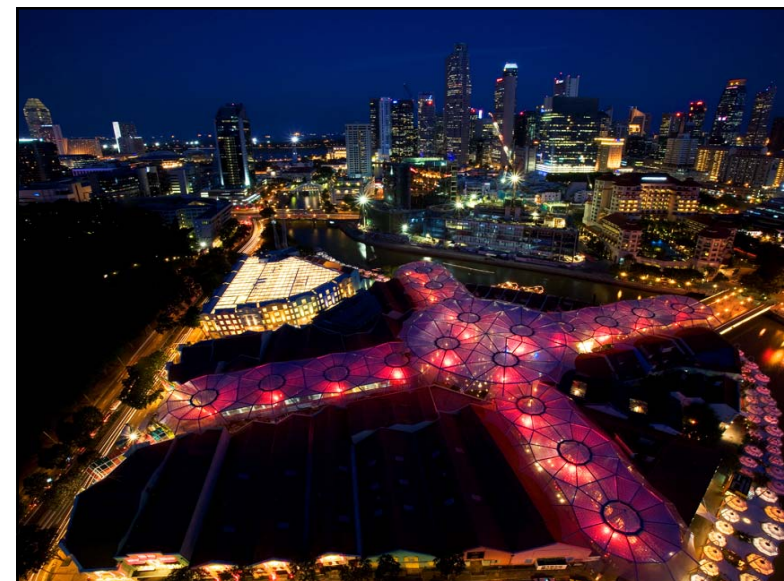
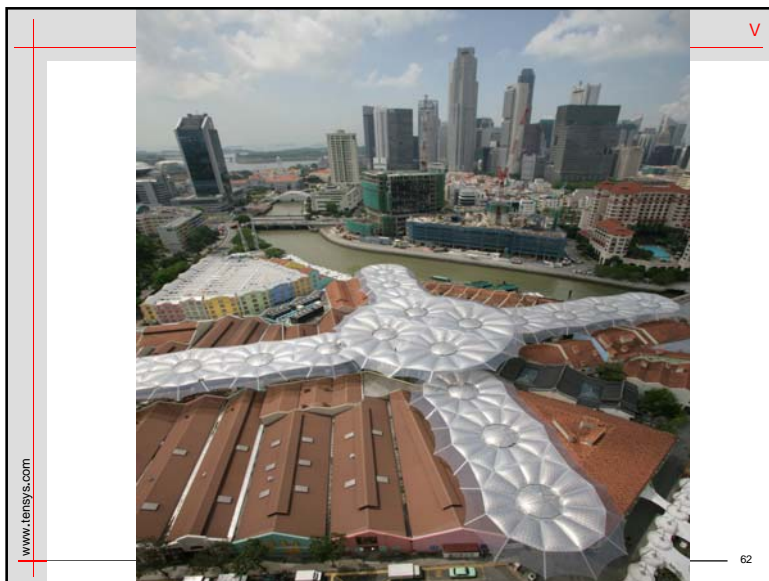
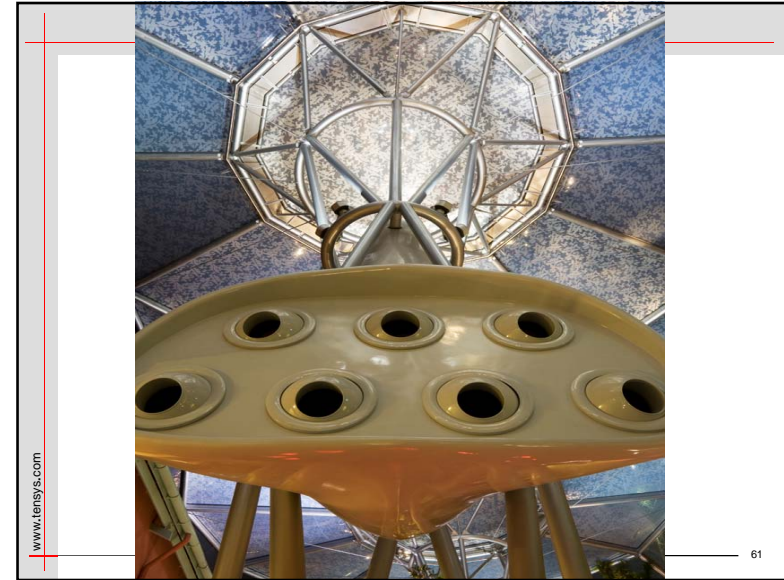
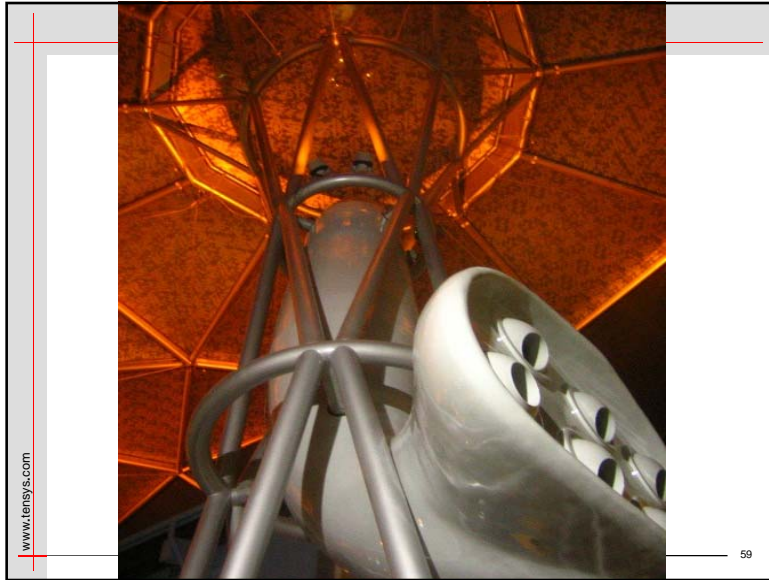

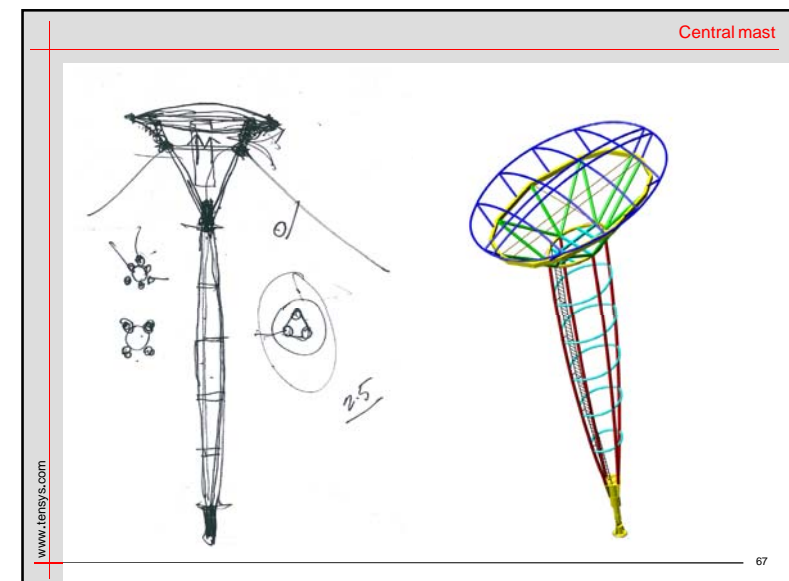
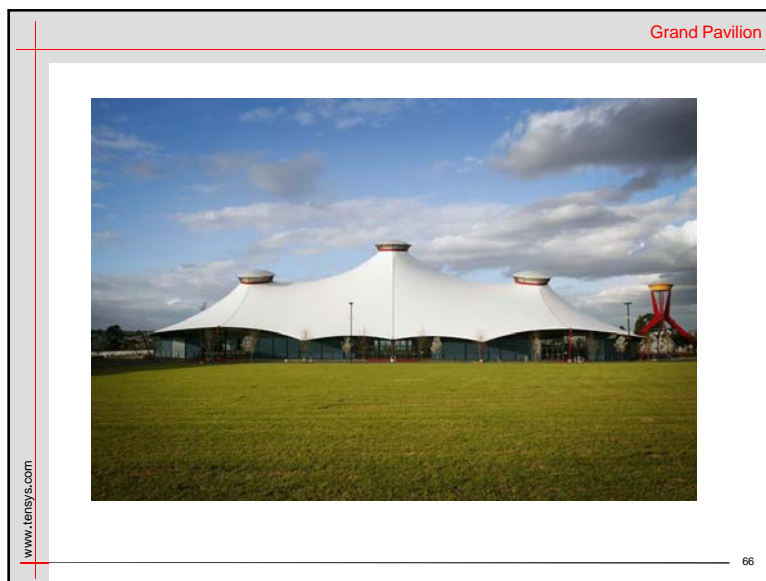
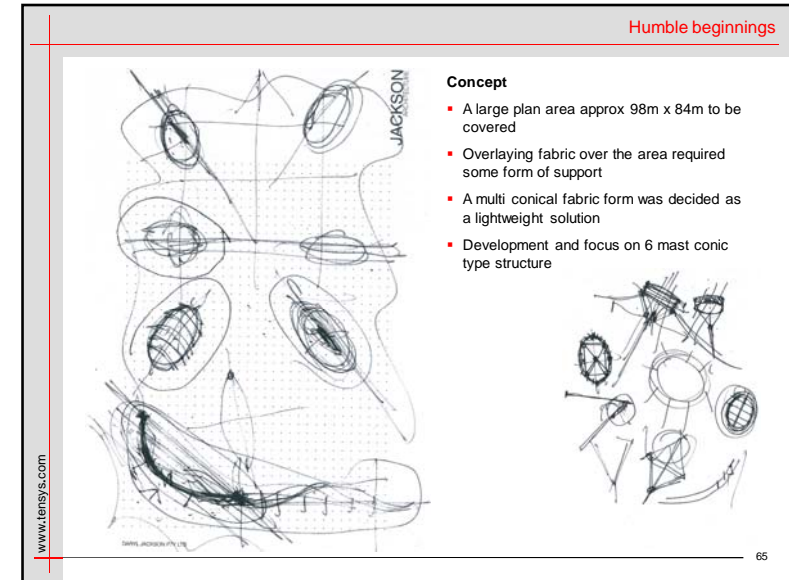

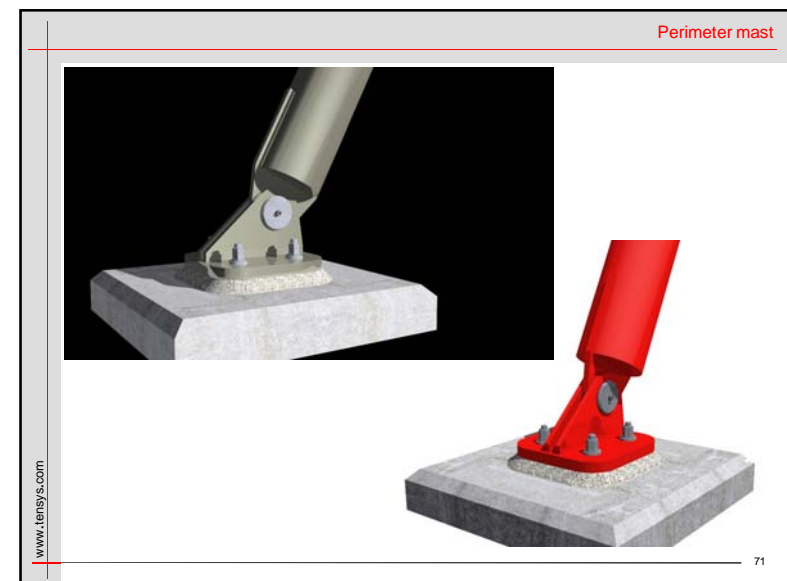
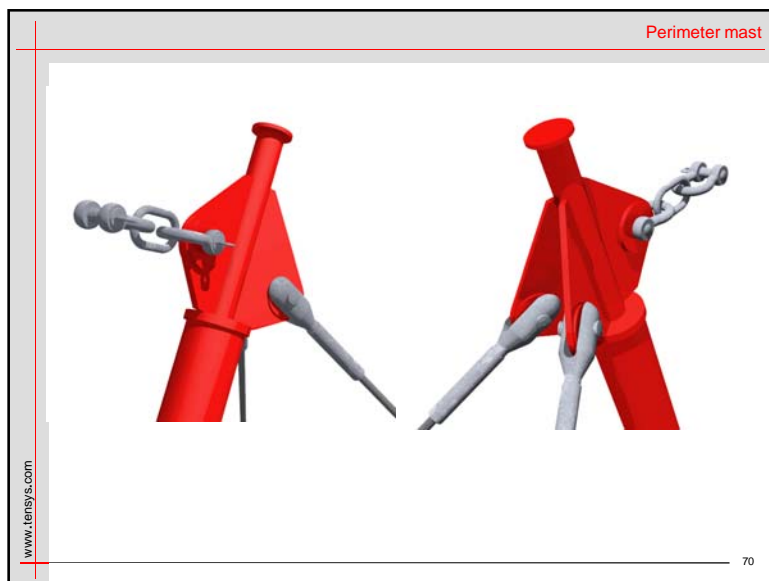
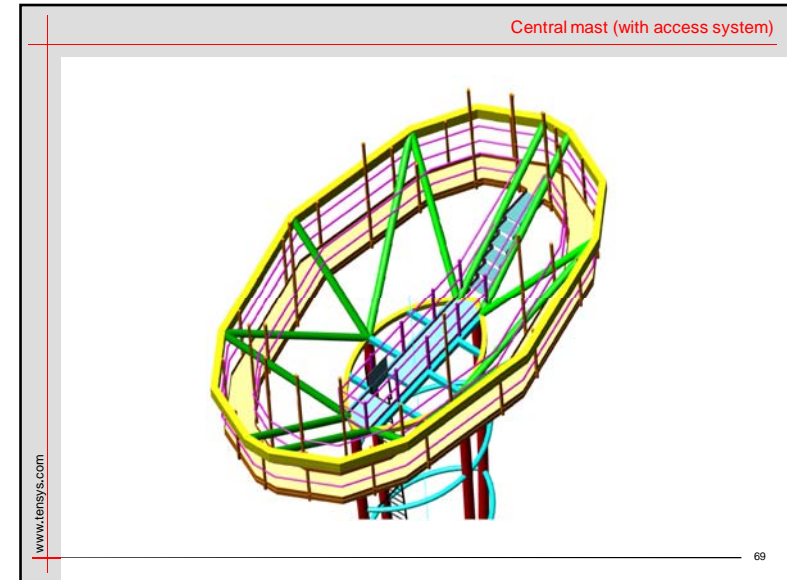
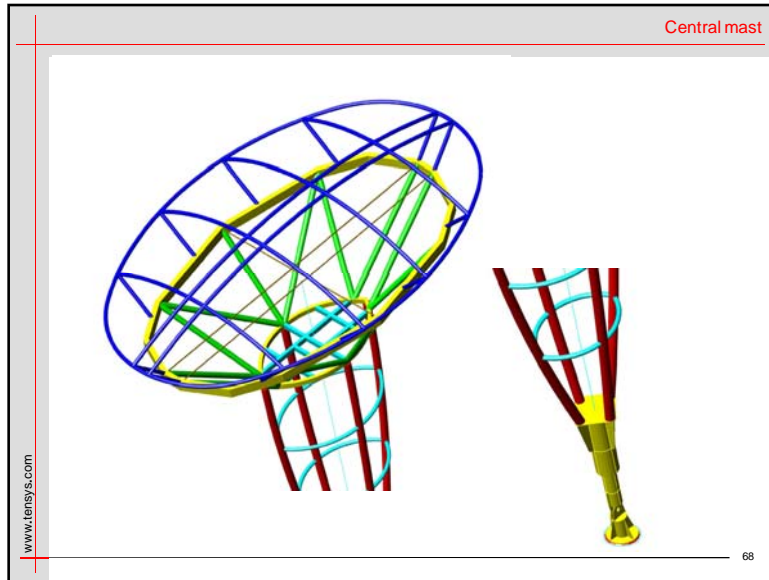

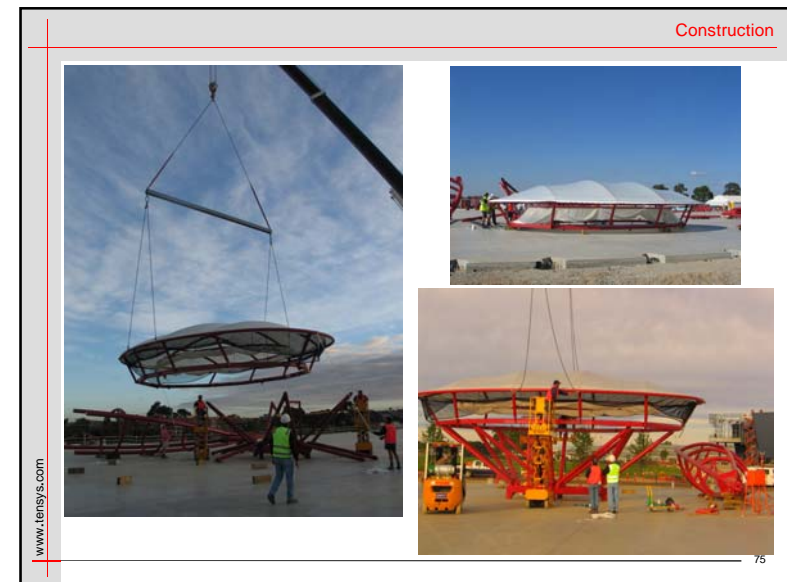
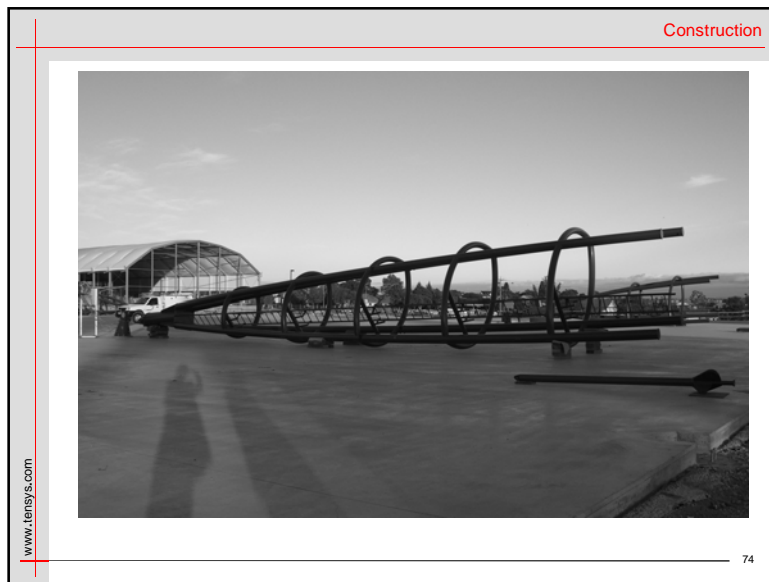
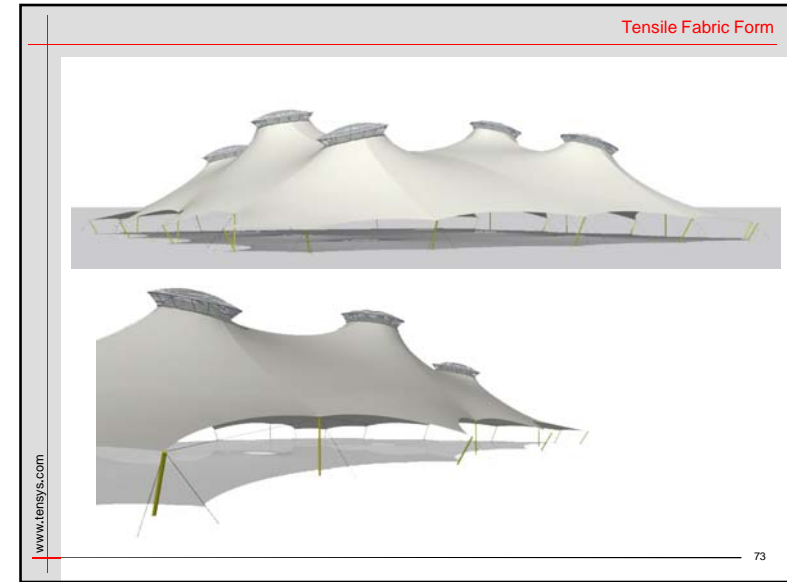

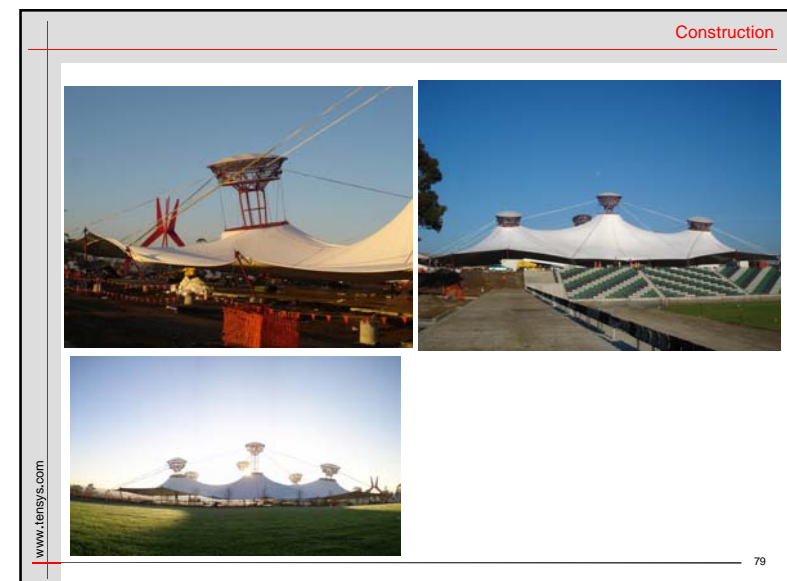
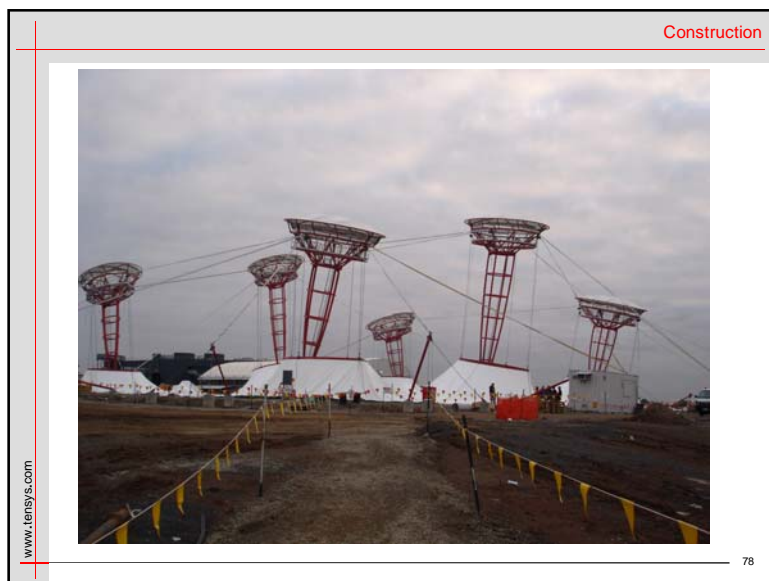
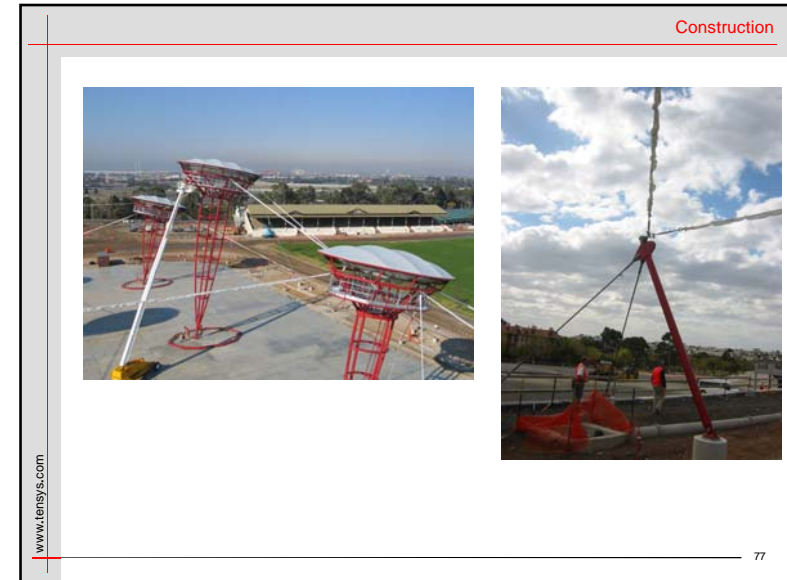

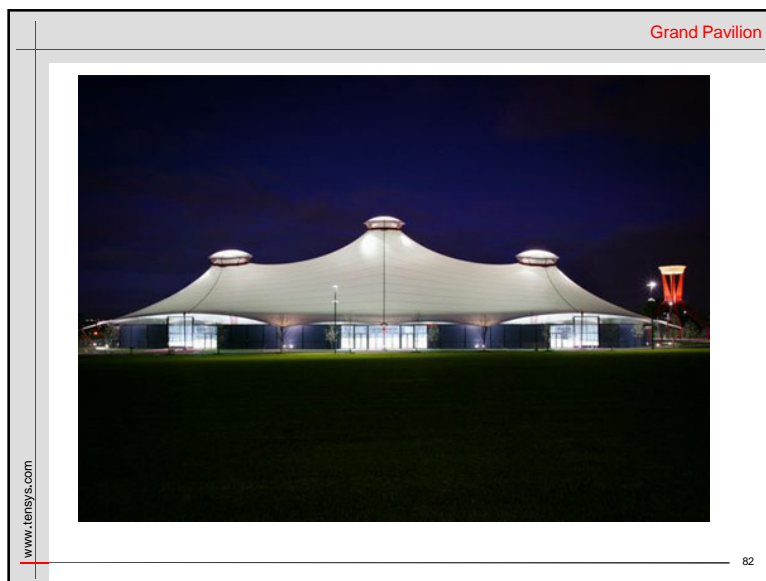
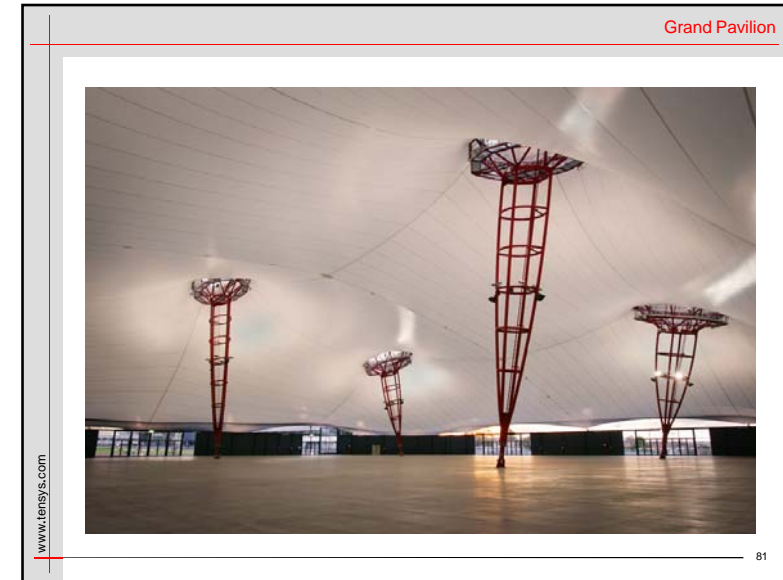
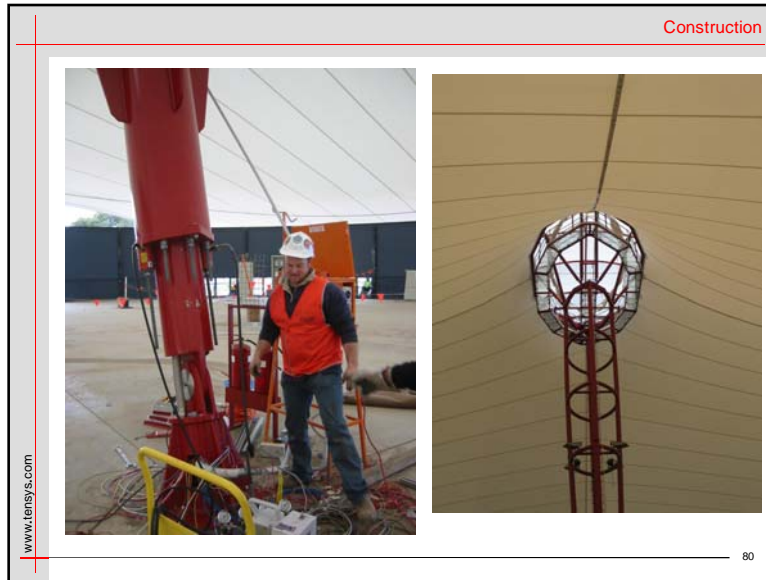

In An Engineer Imagines,

Peter Rice believed that the limits of what can be designed and built are the limitation of materials and the limitation of the designer's inventiveness, not the case of limitation of analysis and specification methods

83